



11A 700V N-CHANNEL POWER MOSFET

TO-263-2L(Prefix :G)

Description

The power MOSFET using **super junction** technology that can realize very low on-resistance and gate charge. It will provide much high efficiency by using optimized charge coupling technology. These user friendly devices give an advantage of Low EMI to designers as well as low switching loss.

Features

- $R_{DS(ON)} \leq 0.38 \Omega @ V_{GS}=10V, I_D=5.5A$
- Fast switching capability
- Low On-Resistance
- 100% Avalanche tested
- 100% ΔV_{DS} tested

Mechanical data

- Case: TO-263-2L
- Approx. Weight:1.52g (0.049oz)
- RoHS compliant
- Case Material: "Green" molding compound, UL flammability classification 94V-0, "Halogen-free".

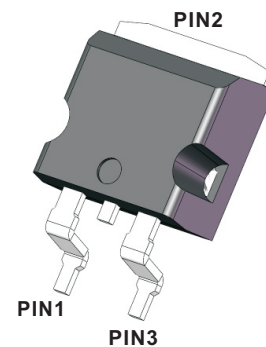

ROHS
COMPLIANT

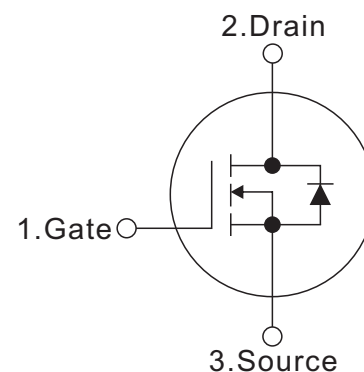

Absolute Maximum Ratings (Ta=25°C, Unless Otherwise Specified)

Parameter	Symbols	Ratings	Units
Drain-Source Voltage	V_{DS}	700	V
Gate-Source Voltage	V_{GS}	± 30	V
Continuous Drain Current	I_D	11 7	A
		$T_c=25^\circ C$ $T_c=100^\circ C$	
Pulsed Drain Current (Note 2)	I_{DM}	42	A
Avalanche Energy Single Pulsed (Note 3)	E_{AS}	125	mJ
Power Dissipation ($T_c = 25^\circ C$)	P_D	62	W
Operating junction and storage temperature	T_J, T_{STG}	-55 ~ +150	$^\circ C$

Notes:

1. Absolute maximum ratings are those values beyond which the device could be permanently damaged. Absolute maximum ratings are stress ratings only and functional device operation is not implied.
2. Repetitive Rating: Pulse width limited by maximum junction temperature.
3. $L=10mH, V_{DD}=50V, R_G=25\Omega, \text{Starting } T_J=25^\circ C$

Thermal Resistance

Parameter	Symbols	Ratings	Units
Thermal resistance, junction – case.	R_{thJC}	2	$^\circ C/W$
Thermal resistance, junction – ambient(min. footprint)	R_{thJA}	63	$^\circ C/W$



Electrical Characteristics (Ta=25°C, Unless Otherwise Specified)

Parameter	Symbols	Test Conditions	Min	Typ	Max	Units
Off Characteristics						
Drain-Source Breakdown Voltage	BV_{DSS}	$V_{GS}=0V, I_D=250\mu A$	700			V
Drain-Source Leakage Current	I_{DSS}	$V_{DS}=700V, V_{GS}=0V$			1.0	μA
Gate- Source Leakage Current	Forward	I_{GSS}			100	nA
	Reverse				-100	
On Characteristics						
Gate Threshold Voltage	$V_{GS(TH)}$	$V_{DS}=V_{GS}, I_D=250\mu A$	2.5		4.5	V
Static Drain-Source On-State Resistance	$R_{DS(ON)}$	$V_{GS}=10V, I_D=5.5A$		0.32	0.38	Ω
Transconductance	g_{fs}	$V_{DS}=20V, I_D=5.5A$		5		S
Dynamic Characteristics						
Input Capacitance	C_{ISS}	$V_{DS}=25V,$ $V_{GS}=0V,$ $f=1.0MHz$		1580		pF
Output Capacitance	C_{OSS}			454		pF
Reverse Transfer Capacitance	C_{RSS}			19		pF
Gate resistance	R_G	$V_{DS}=0V, FREQ=1.00MHz$		5		Ω
Switching Characteristics						
Total Gate Charge (Note 1)	Q_G	$V_{DS}=480V, V_{GS}=10V,$ $I_D=5.5A$ (NOTE1,2)		26		nC
Gate-Source Charge	Q_{GS}			6.8		nC
Gate-Drain Charge	Q_{GD}			8.4		nC
Turn-On Delay Time (Note 1)	$t_{D(ON)}$	$V_{DS}=400V, I_D=5.5A$ $R_G=25\Omega, V_{GS}=10V$ (NOTE1,2)		20		ns
Turn-On Rise Time	t_R			28		ns
Turn-Off Delay Time	$t_{D(OFF)}$			76		ns
Turn-Off Fall Time	t_F			15		ns
Drain-Source Diode Characteristics And Maximum Ratings						
Maximum Body-Diode Continuous Current	I_S				11	A
Drain-Source Diode Forward Voltage (Note 1)	V_{SD}	$I_{SD}=11A, V_{GS}=0V$			1.2	V
Reverse Recovery Time (Note 1)	t_{rr}	$I_F=5.5A$ $di/dt=100A/\mu s$		290		ns
Reverse Recovery Charge	Q_{rr}			4.5		μC

Notes:

1. Pulse Test: Pulse width $\leq 300\mu s$, Duty cycle $\leq 2\%$.
2. Essentially independent of operating temperature.



Test Circuits and waveforms

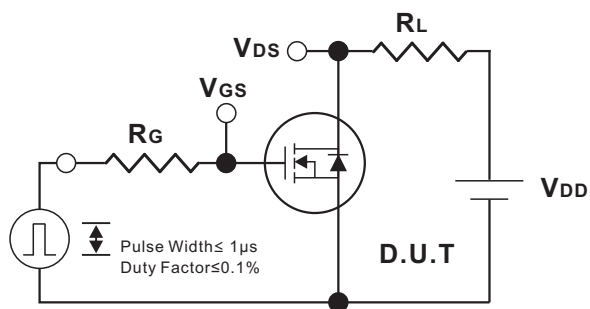

Switching Test Circuit

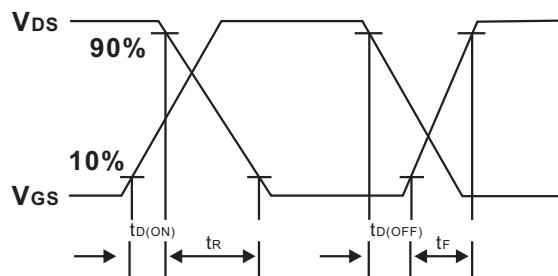

Switching Waveforms

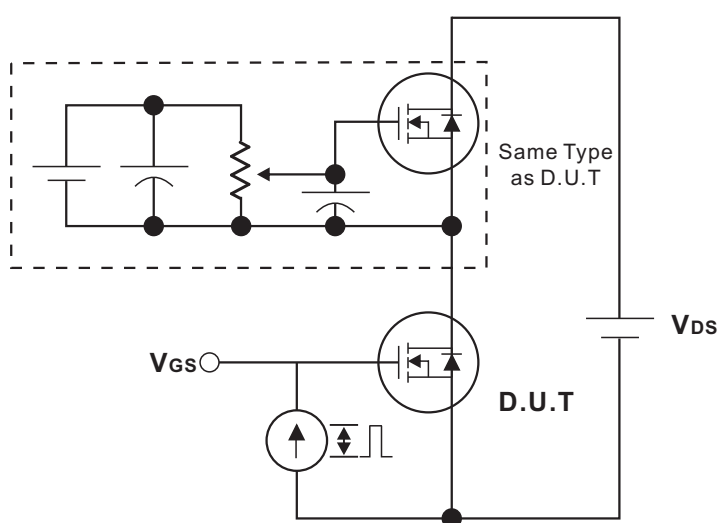

Gate Charge Test Circuit

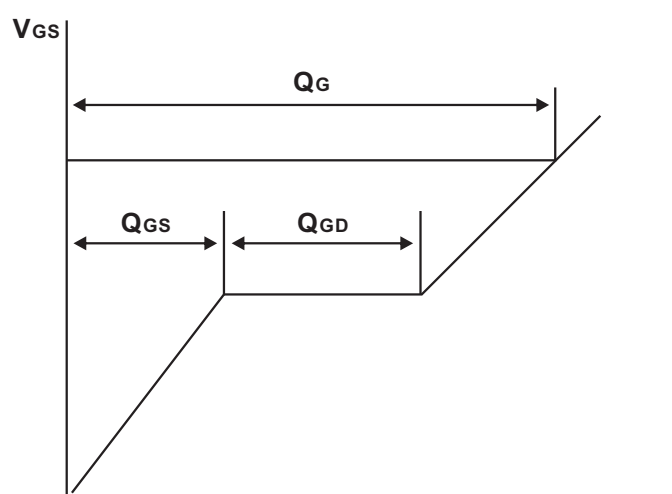

Charge
Gate Charge Waveform

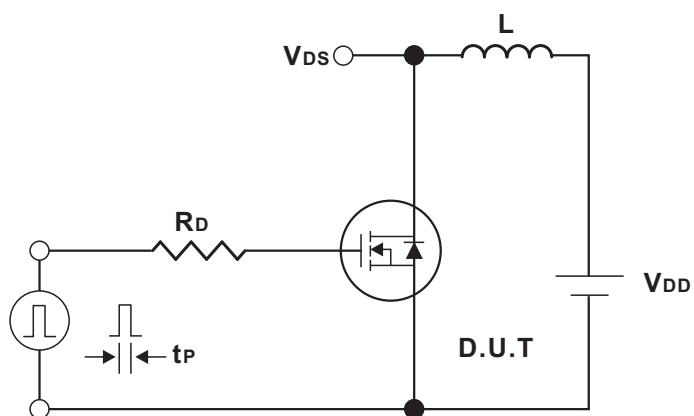

Unclamped Inductive Switching Test Circuit

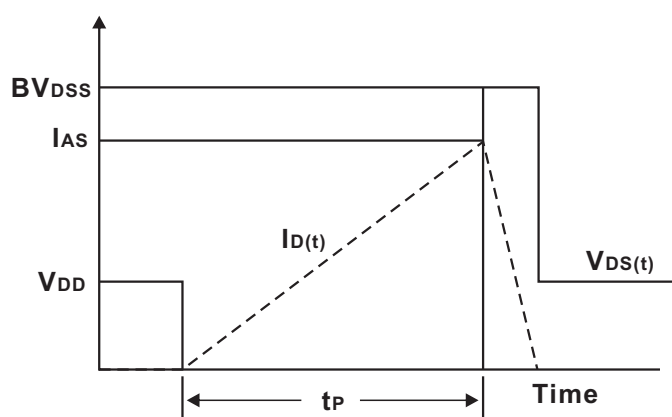

Unclamped Inductive Switching Waveforms



Test Circuits and waveforms

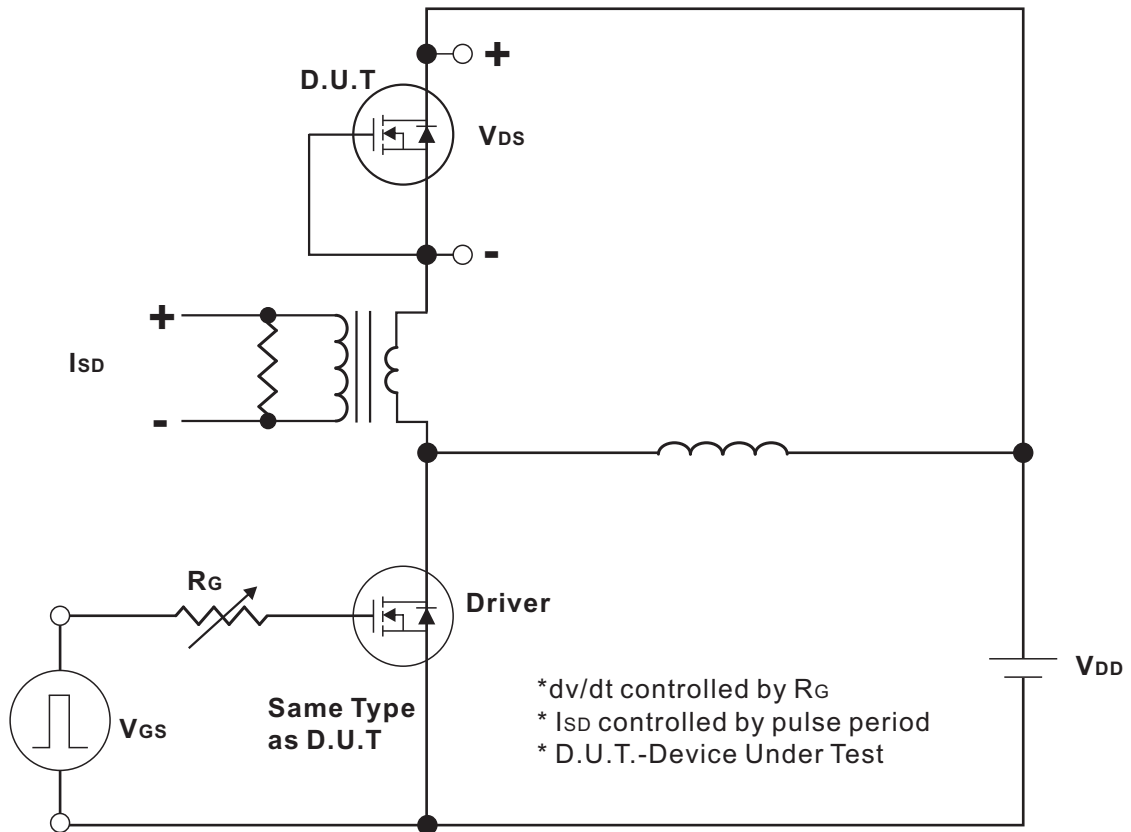

Peak Diode Recovery dv/dt Test Circuit

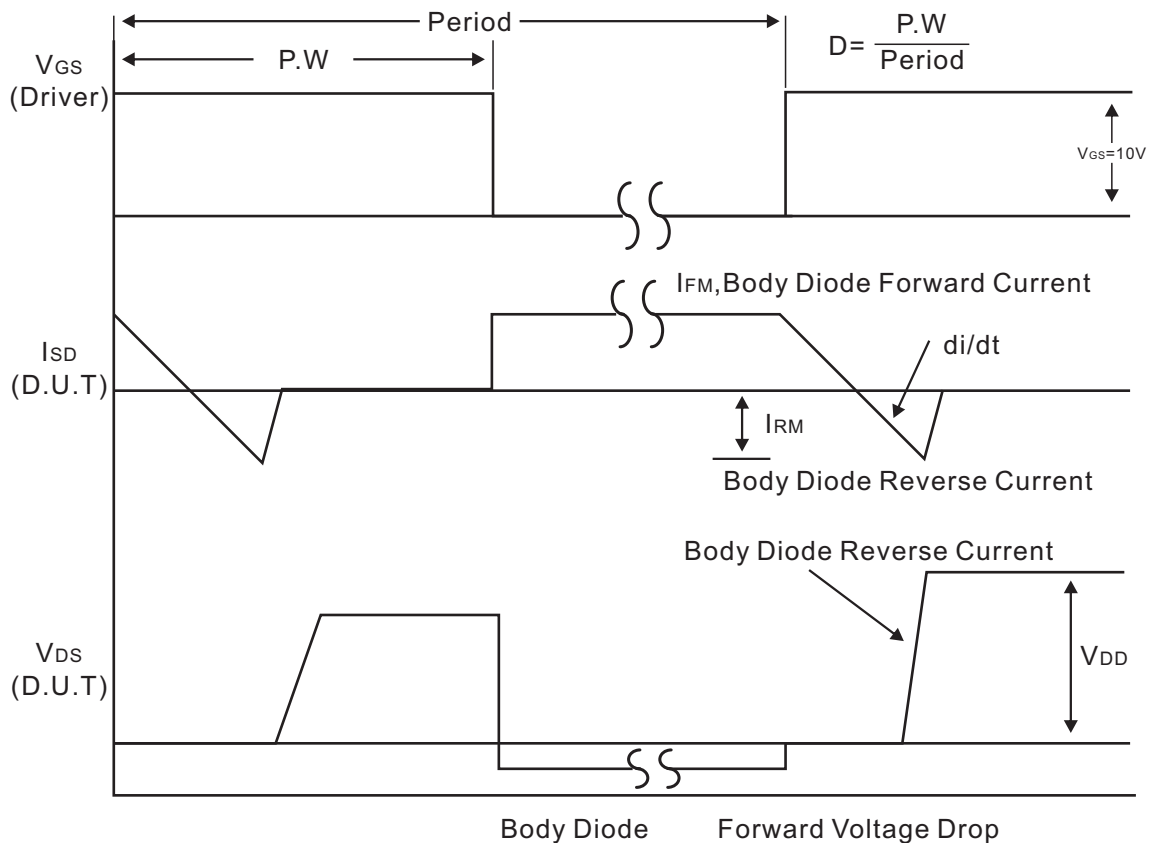

Peak Diode Recovery dv/dt Waveforms



Typical Characteristics

Fig.1 Output characteristics

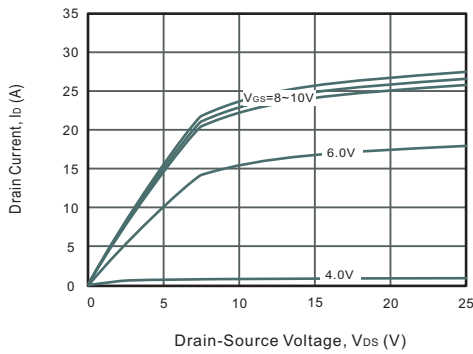

Fig.2 Power Dissipation

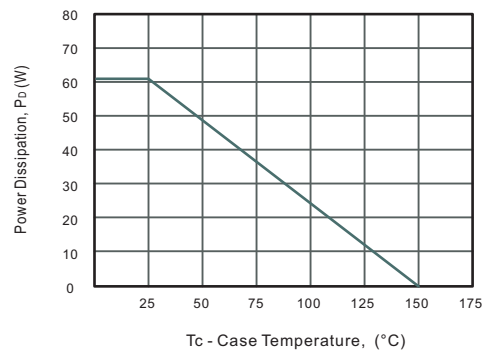

Fig.3 Drain Current Derating

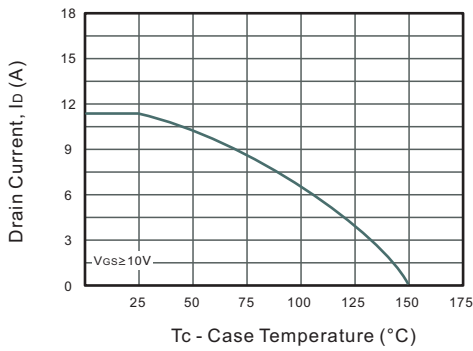

Fig.4 Drain-Source On-Resistance vs. Drain Current

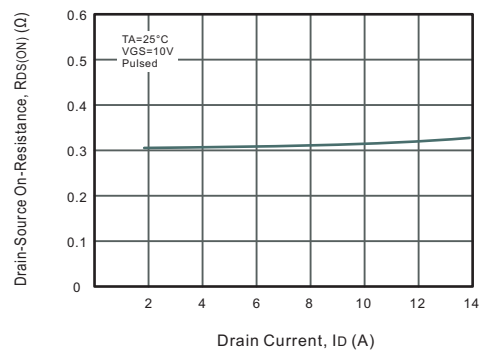

Fig.5 Gate Threshold Voltage vs. Junction Temperature

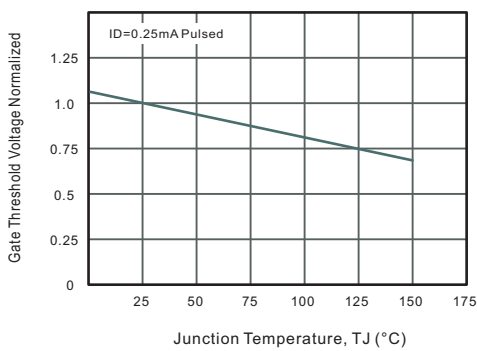

Fig.6 Body-diode Forward Characteristics

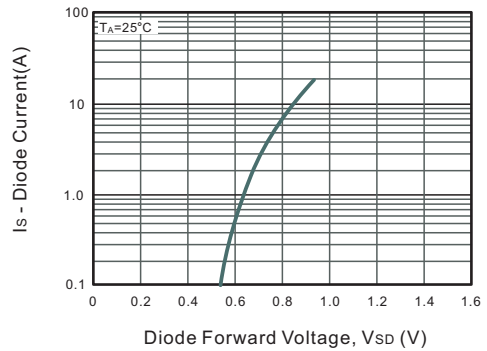

Fig.7 Drain-Source On-Resistance vs. Junction Temperature

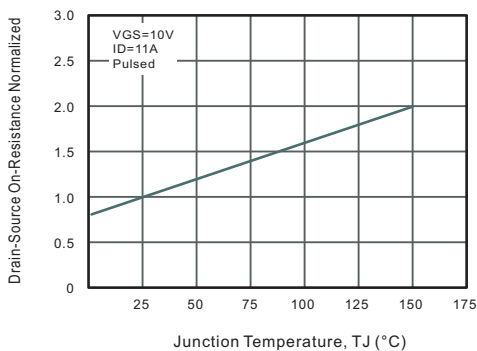
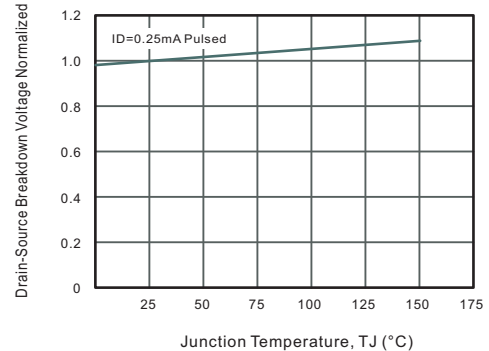

Fig.8 Breakdown Voltage vs. Junction Temperature





Typical Characteristics

Fig.9 Capacitance Characteristics

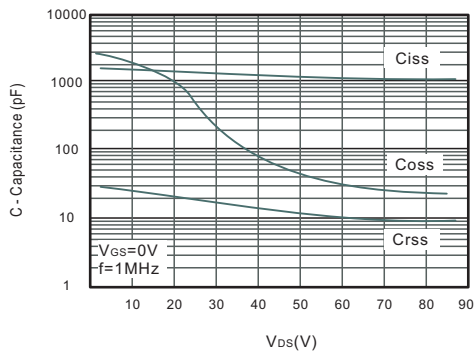

Fig.10 Gate Charge Characteristics

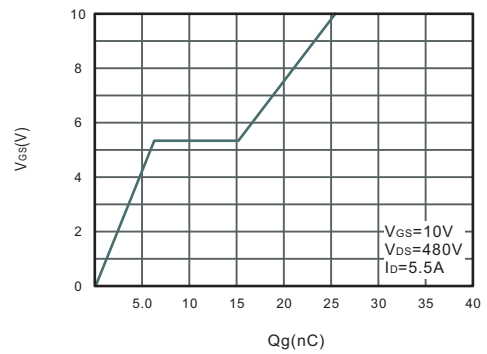

Fig.11 Safe Operating Area

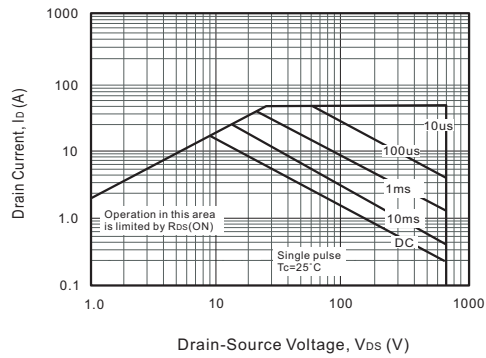
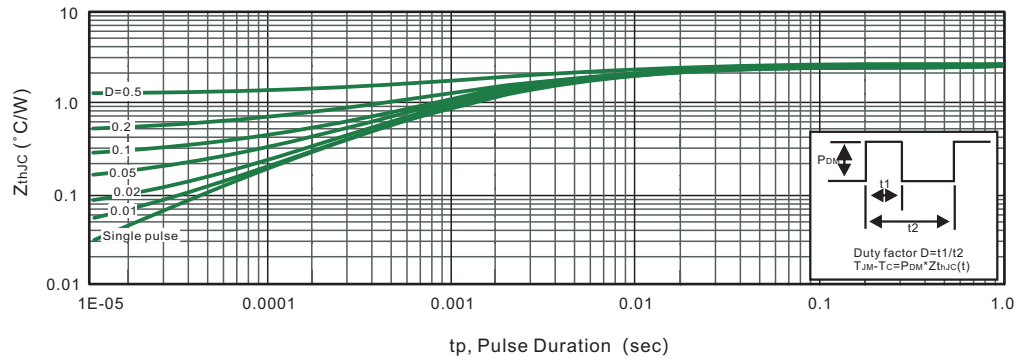

Fig.12 Max. Transient Thermal Impedance





Package Outline
Plastic surface mounted package; 2 leads

TO-263-2L

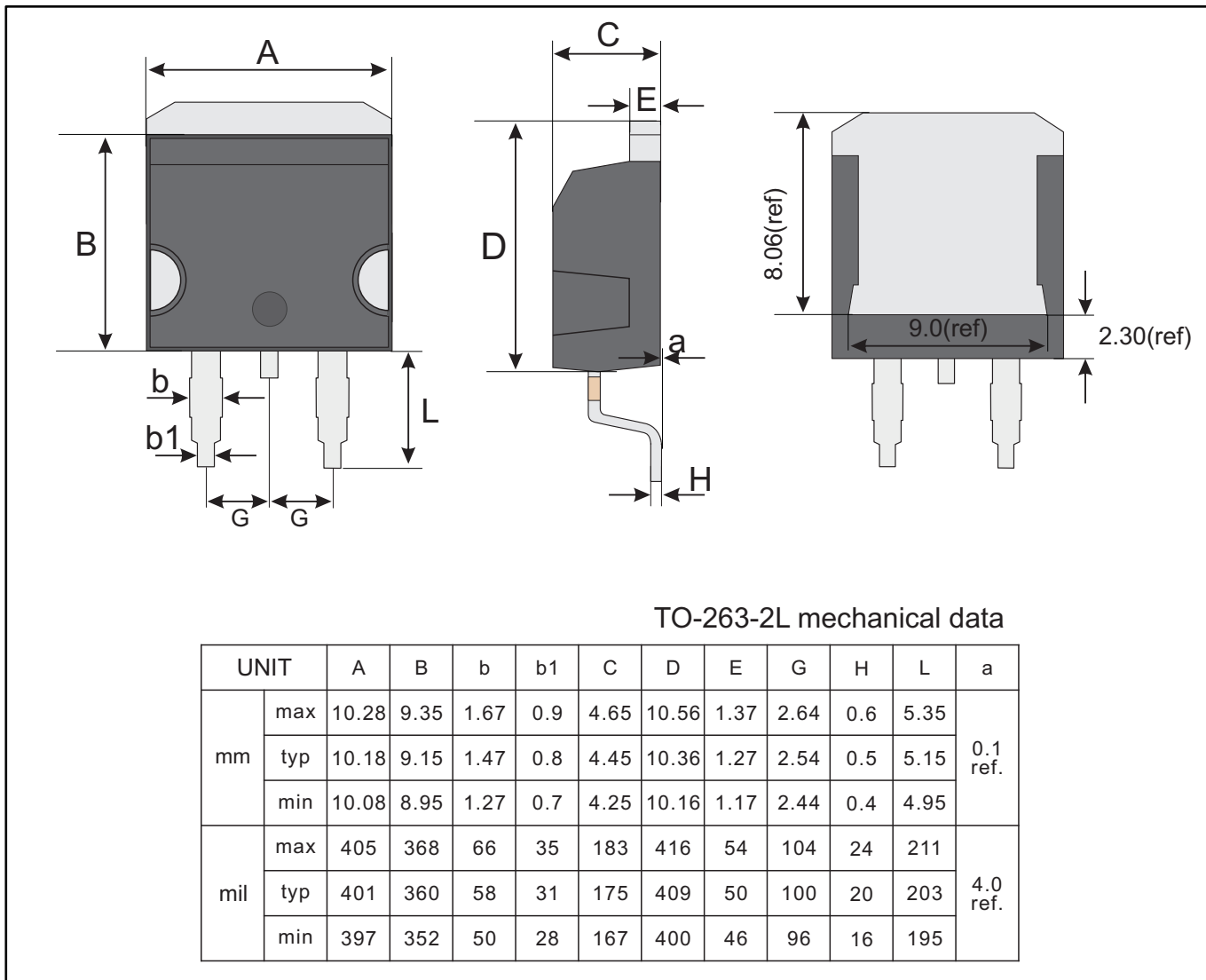

Marking

Type number	Marking code
G70R380TP1	G70R380TP1

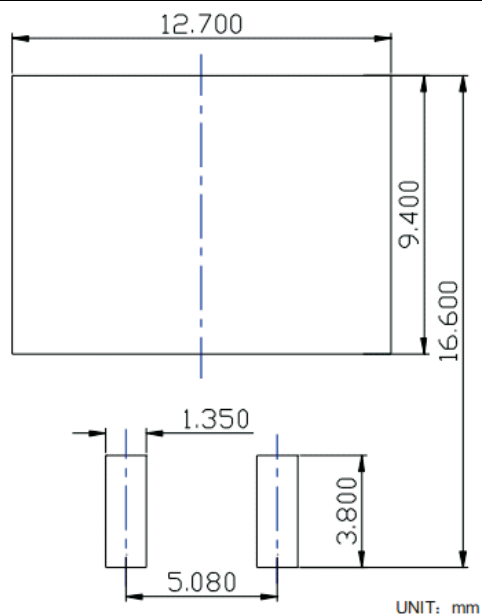

SUGGESTED SOLDER PAD LAYOUT



Important Notice and Disclaimer

Jingdao Microelectronics reserves the right to make changes to this document and its products and specifications at any without notice.

Customers should obtain and confirm the latest product information and specifications before final, purchase or use.

Jingdao Microelectronics makes no warranty, representation or guarantee regarding the suitability of its products for any particular purpose, not does Jingdao Microelectronics assume any liability for application assistance or customer product design.

Jingdao Microelectronics does not warrant or accept any liability with products which are purchased or used for any unintended or unauthorized application.

No license is granted by implication or otherwise under any intellectual property rights of Jingdao Microelectronics.

Jingdao Microelectronics products are not authorized for use as critical components in life support devices or systems without express written approval of Jingdao Microelectronics.